

# A New Dealer's In Town

Or,  
Smoke 'Em if You Got 'Em

## Stage 1

10 Pistol  
10 Rifle  
2+ Shotgun

### Story:

Sheriff Fred White is showing you and your brothers around Tombstone. All the saloons and gaming houses are bustling except for the Oriental. The sheriff tells you that the Oriental is a real slaughterhouse. Leaving your brothers and the sheriff in the street, you walk in and meet the owner. He tells you that the faro dealer named Johnny Tyler has run away all of the business. You walk over and tell him that he is setting in your chair. He stands, angry, and puts his hand on his revolver. Facing him, you say, "Go ahead, skin that smoke wagon."

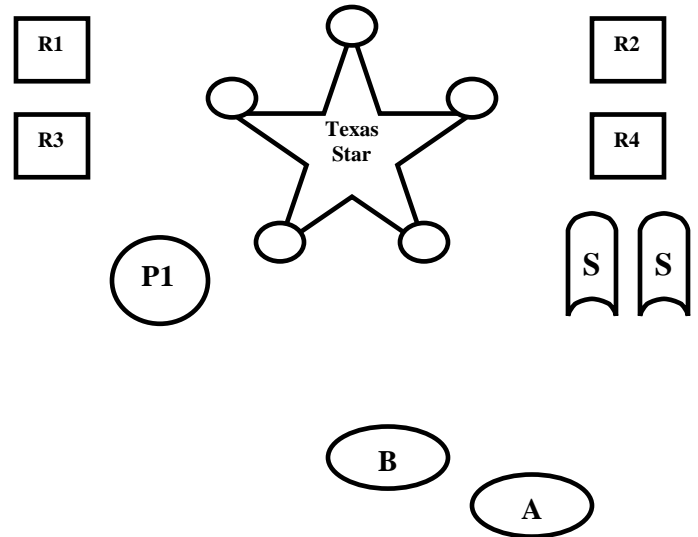

### Starting Position:

Standing at "A" with both hands on your pistols.

### Staging:

Two pistols loaded and holstered.

Rifle on the rest at A

Shotgun on the rest at B.

### Procedure:

When ready yell, "**Go ahead, skin that smoke wagon.**"

ATB...Pick up the rifle and double tap the top two rifle targets then triple tap the bottom two rifle targets. Safely stage the rifle, and...

Move to B and, with your pistols, per your shooting style, alternate between P1 and the star, starting on P1. After knocking off all 5 Texas Star targets, dump any remaining rounds into P1. Holster, and...

Pick up the shotgun, load and knock off any remaining Star targets, then knock down the two shotgun targets.

**Note: Pistol misses are the targets left on the Texas Star and/or any misses on P1.**

# Gunfight at the OK Corral

Or,  
**Don't Wink at Me!**

## Stage 2

10 Pistol  
10 Rifle  
2+ Shotgun

### Story:

The McLaury's and the Clanton's are down on Freemont Street near the OK corral. The Earp's have had enough, and head down there to disarm them. Joined by Doc Holiday, you walk straight toward the corral. Virgil yells for them to throw up their hands. Time stands still. Then Doc winks at Billy Clanton, and the fight is about to start.

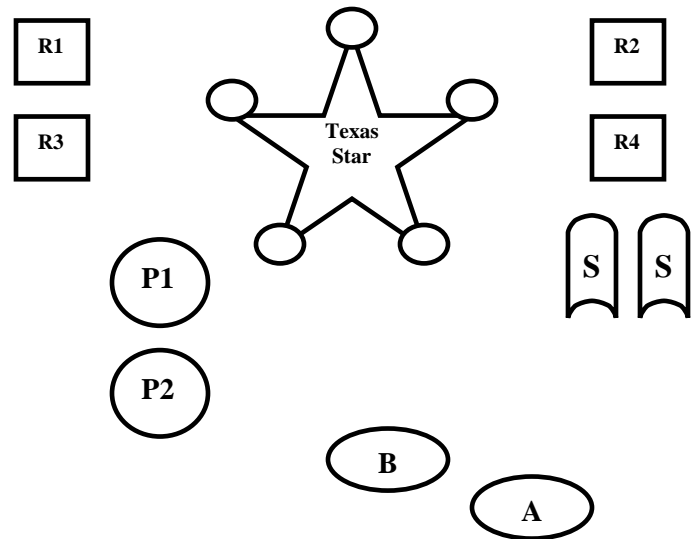

### Starting Position:

Standing at "A" with the rifle held at cowboy port arms.

### Staging:

Two pistols loaded and holstered.  
Rifle at cowboy port arms.  
Shotgun on the rest at B.

### Procedure:

When ready yell, "**Throw up your hands, we're here to disarm you.**"

ATB...With the rifle, knock off all of the star targets. Shoot any remaining rifle rounds into the rifle target of your choice. Safely stage the rifle, and...

Move to B and, with your pistols, per your shooting style, double tap P1 and Triple tap P2. Holster...and repeat with 2<sup>nd</sup> pistol. Holster, and...

Pick up the shotgun, load and knock off any remaining Star targets, then knock down the two shotgun targets.

**Note: Rifle misses are the targets left on the Texas Star and/or any misses on the rifle targets.**

# I'm Your Huckleberry!

Or,  
What is a Huckleberry?

## Stage 3

10 Pistol
10 Rifle
4 Shotgun

### Story:

A very drunk Johnny Ringo, staggers up to the Earps and proclaims, "I want your blood. And I want your soul!" Wyatt, being unarmed, tells Ringo, "I won't fight you, there's no money in it." You stand up from the barber chair and move closer. "I'm your huckleberry," you tell Ringo, "that's just my game."

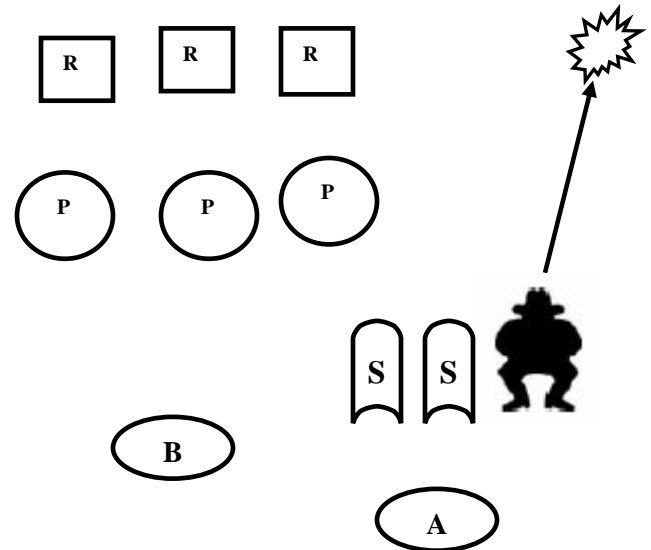

### Starting Position:

Standing at "A" with one hand behind your back and the other hand on a pistol grip.

### Staging:

Two pistols loaded and holstered.  
Rifle on rest at B  
Shotgun on rest at A.

### Procedure:

When ready say, "I'm your huckleberry!".

At the buzzer...

Pick up your shotgun and engage the cowboy shotgun target then the aerial bird. Breaking the bird in the air is a bonus (you must engage the bird). Then knock down the other two shotgun targets. Safely stage shotgun on the rest...

Move to position B, and pick up your rifle, engage the rifle targets in the following order, R1, R2, R2, R3, R2, R2, R1, R2, R2, R3. Safely stage the rifle on the rest...

Draw your pistols per your shooting style and engage the pistol targets the same as your rifle.

# Tell 'em I'm Comin'!

Or,  
Please Take a Message.

## Stage 4

10 Pistol
10 Rifle
4 Shotgun

### Story:

The Cowboys have maimed your brother Virgil and killed your brother Morgan. You have to get your family to safety. Frank Stillwell and Ike Clanton sneak up on the train car and ask, "Where the hell's Wyatt?" You respond, "Behind you Frank." You let loose with your scattergun and Frank falls dead. Ike falls to the ground and begs for his life. Instead of killing him, you send him back with a message for all of the Cowboys. You tell him, "You tell 'em I'm comin', and hell's comin' with me."

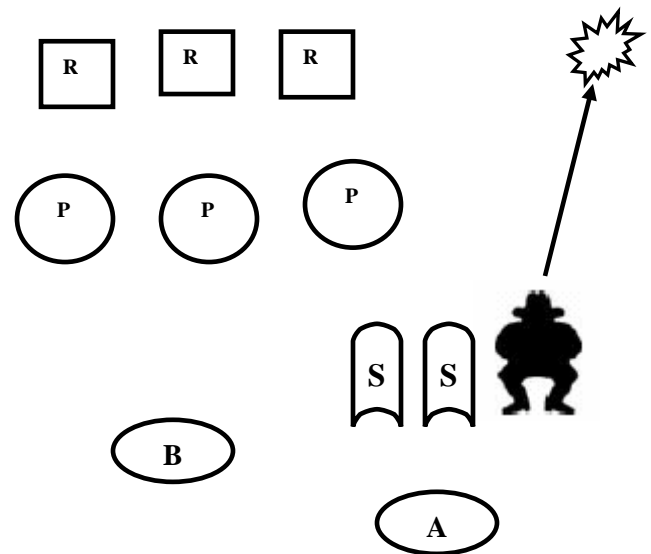

### Starting Position:

Standing at "A" with your shotgun held at cowboy port arms.

### Staging:

Two pistols loaded and holstered.  
Rifle on rest at A  
Shotgun at port arms.

### Procedure:

When ready say, "**You tell 'em I'm comin' and hell's comin' with me!**"

At the buzzer...

Pick up your shotgun and engage the cowboy shotgun target then the aerial bird. Breaking the bird in the air is a bonus (you must engage the bird). Then knock down the other two shotgun targets. Safely put shotgun on rest..

Pick up your rifle, engage the rifle targets in a continuous double tap Nevada sweep. Safely stage the rifle on the rest...

Move to position B and per your shooting style, engage the pistol targets the same as your rifle.

# The Vendetta Rides On!

Or,  
I Hate Red Sashes.

## Stage 5

10 Pistol
10 Rifle
8 Shotgun

### Story:

The Vendetta Ride sweeps across the plains. You proclaim to the Cowboys, "If I see a red sash, I'll kill the man wearing it."

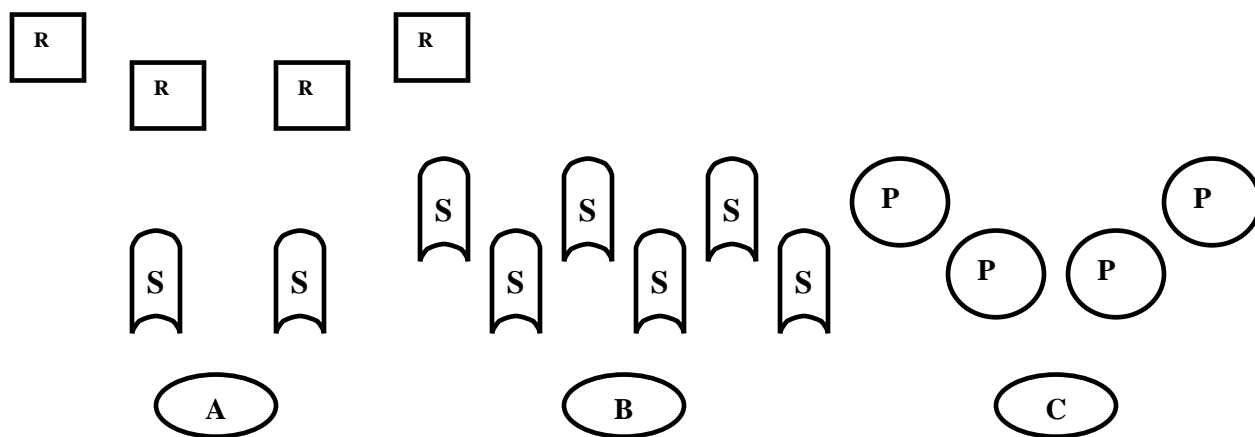

#### Starting Position:

Standing at position A with both hands on your hat.

#### Staging:

Two pistols loaded and holstered.  
Rifle on the rest at A  
Shotgun on the rest at A

#### Procedure:

When ready yell, "If I see a red sash, I'll kill the man wearing it!"

At the buzzer...

Pick up the rifle and shoot the four rifle targets in this order - 1, 2, 2, 3, 4, 4, 3, 2, 2, 1... Safely stage the rifle, and...

Pick up the shotgun, knock down the two shotgun targets, and safely move to position B... Knock down the six targets, safely stage the shotgun and move to position C...

Draw your pistols per your shooting style and engage the pistol targets the same as your rifle.

**Note: Basketball rule applies on all movement and loading.**

# Let's Finish It!

Or,  
**The Reckoning is Over.**

## Stage 6

10 Pistol
10 Rifle
8 Shotgun

### Story:

Looking around at your friends that have fought by your side and helped bring a reckoning to the Cowboys, you say, "Let's finish it!"

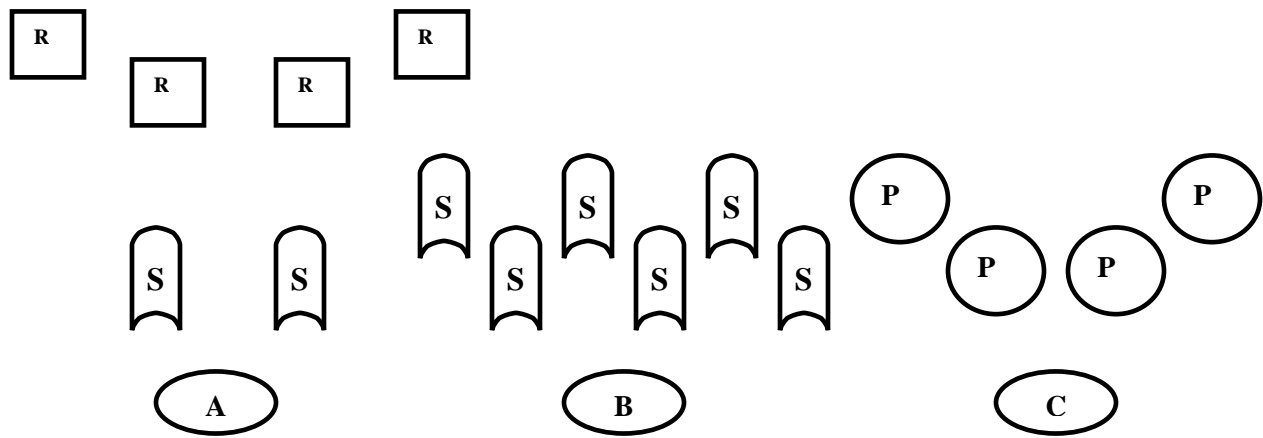

#### Starting Position:

Standing at position A with both hands just above your pistols, but not touching them.

#### Staging:

Two pistols loaded and holstered.  
Rifle on the rest at A  
Shotgun on the rest at A

#### Procedure:

When ready yell, "Let's finish it!"

At the buzzer...

Pick up the shotgun, knock down the two shotgun targets, safely stage your shotgun and ...

Pick up the rifle and shoot the four rifle targets in this order - 1, 1, 1, 1, 2, 2, 2, 3, 3, 4... Safely stage the rifle, and...

Pick up your shotgun, safely move to position B and knock down the six targets. Safely stage your shotgun, and move to position C...

Draw your pistols per your shooting style and engage the pistol targets the same as your rifle.

**Note: Basketball rule applies on all movement and loading.**